

Glitch. The Art That Interfered

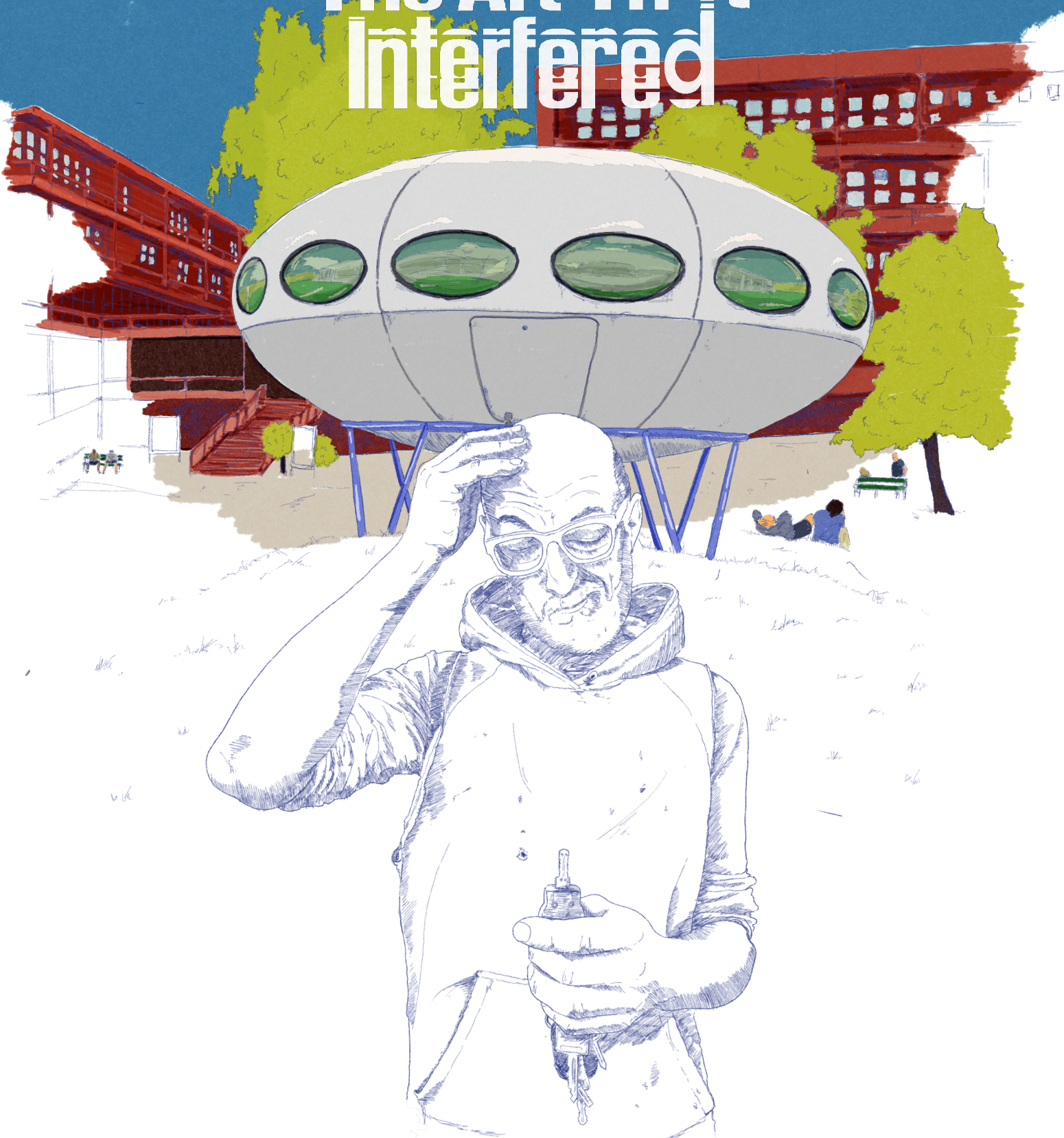

THIS STORY IS BASED ON TRUE EVENTS.

I swear!

THE EVENTS DEPICTED IN THIS COMIC
TOOK PLACE IN MUNICH IN 2024.

FOR THE FUN OF IT, SOME EVENTS
HAVE BEEN EXAGGERATED FOR
DRAMATIC EFFECT AND VIVIDNESS.

IN DEFERENCE OF THE LIVING,
THE REST IS DESCRIBED JUST THE
WAY IT HAPPENED.



...YEAH AND THAT'S WHY I GOT KICKED OUT.

THERE YOU PLAYED UP AGAIN!

WE SHOULD MAKE SOME MOVIE ABOUT THAT...

OR A PUPPET THEATRE PLAY, MAYBE!

WELL...

GLITCH.
THE ART THAT INTERFERED
by
Michael Pfitzner
&
Andreas Farniller

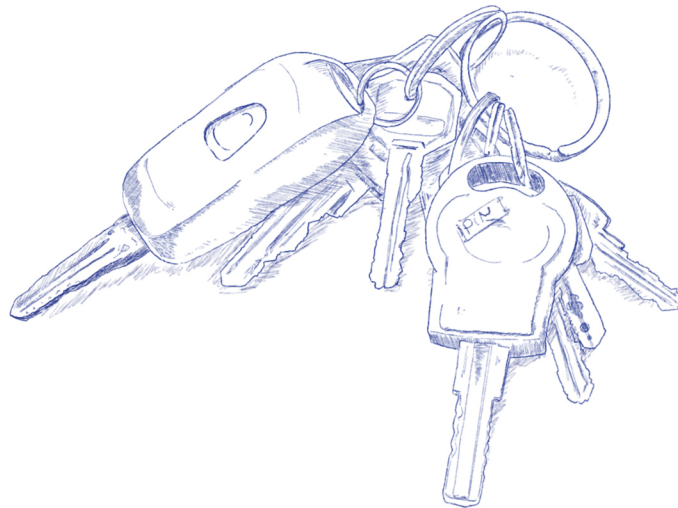

WHAT SHOULD I DO NOW, MICHAEL?

TELL IT ANYWAY!

WELL THEN.



zip
zip

SO MY NAME IS...

ANDREAS FAMILER.

I'M BASICALLY AN ARTIST, BUT I DON'T WANT TO CUT MY EAR OFF, SO...

...I HAVE SEVERAL JOBS, LIKE ALL THE OTHERS.

JUST THE WAY IT IS...



ONE OF MY JOBS IS AT THE ART MUSEUM WHERE I SET UP EXHIBITIONS.

AT SOME POINT I HAD THE IDEA OF PUTTING UP A PICTURE THERE. THAT'S WHY I'M SITTING HERE. BUT WE'LL GET TO THAT.

HONESTLY, WHAT DID THEY EXPECT, HIRING SOMEONE LIKE ME?



whistle
whistle

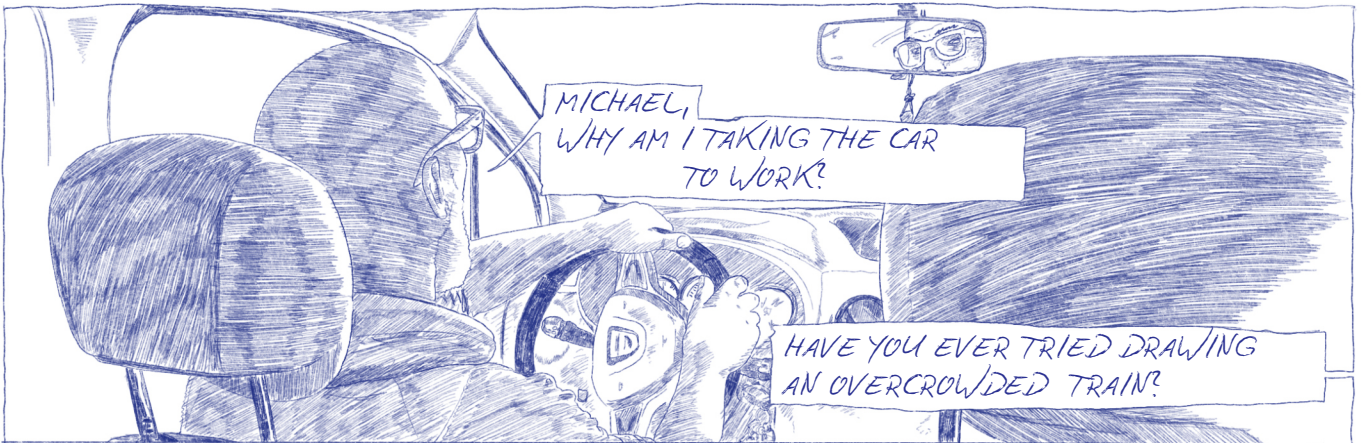
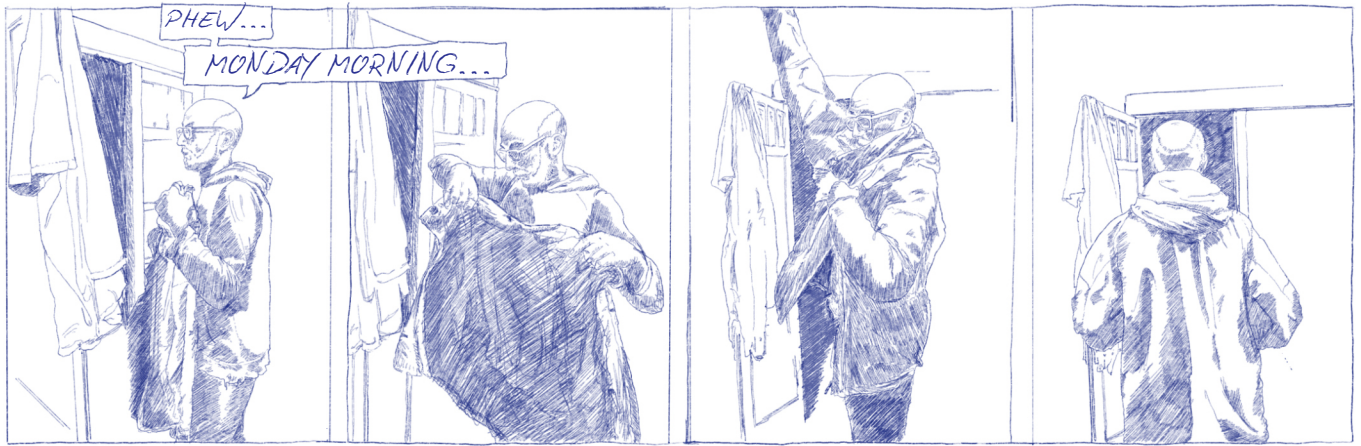



WHY DO YOU FIND MISTAKES SO FASCINATING?

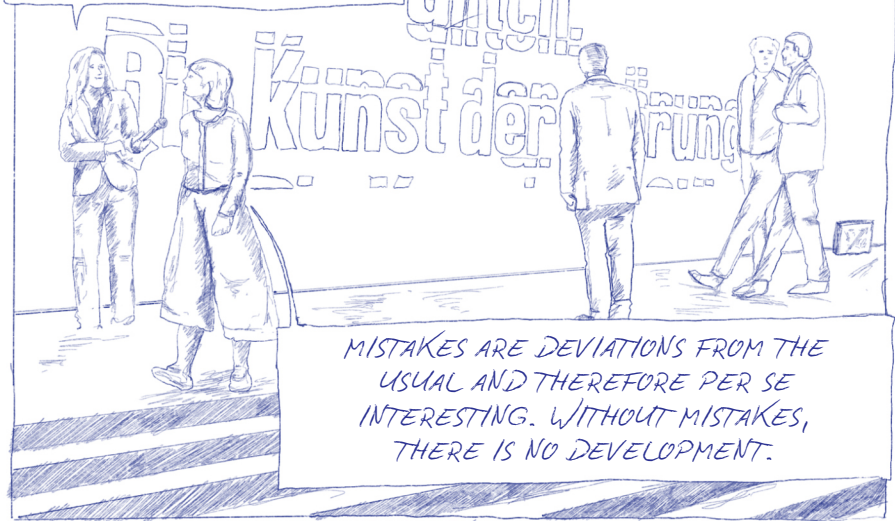

WHAT HAVE YOU LEARNED ABOUT MISTAKES THROUGH THE EXHIBITION?

DURING THE SET UP SOMETHING HAS CHANGED. WE LAUGHED AT EVERY MISHAP AND SAID: THAT WAS ALL PART OF THE PLAN! THERE IS NO PERFECTION. WHO GET'S TO SAY WHAT IS PERFECT AND WHAT ISN'T?! NOW I'M MORE RELAXED ABOUT ACCIDENTS.

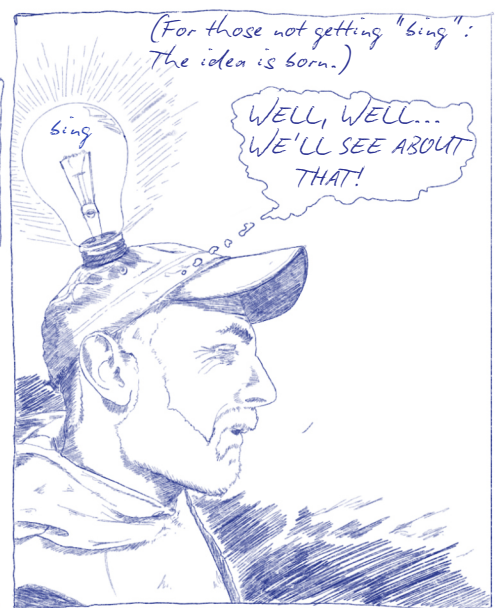
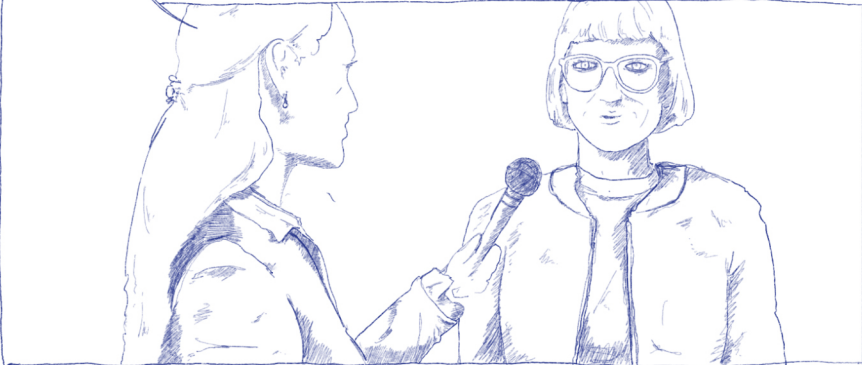

DISPOSING BOTTLES ON SUNDAY!

IT'S A NO-GO.

WHOA, THE LIGHT IS TOO BRIGHT!

AH... IT'S GOING THIS WAY.



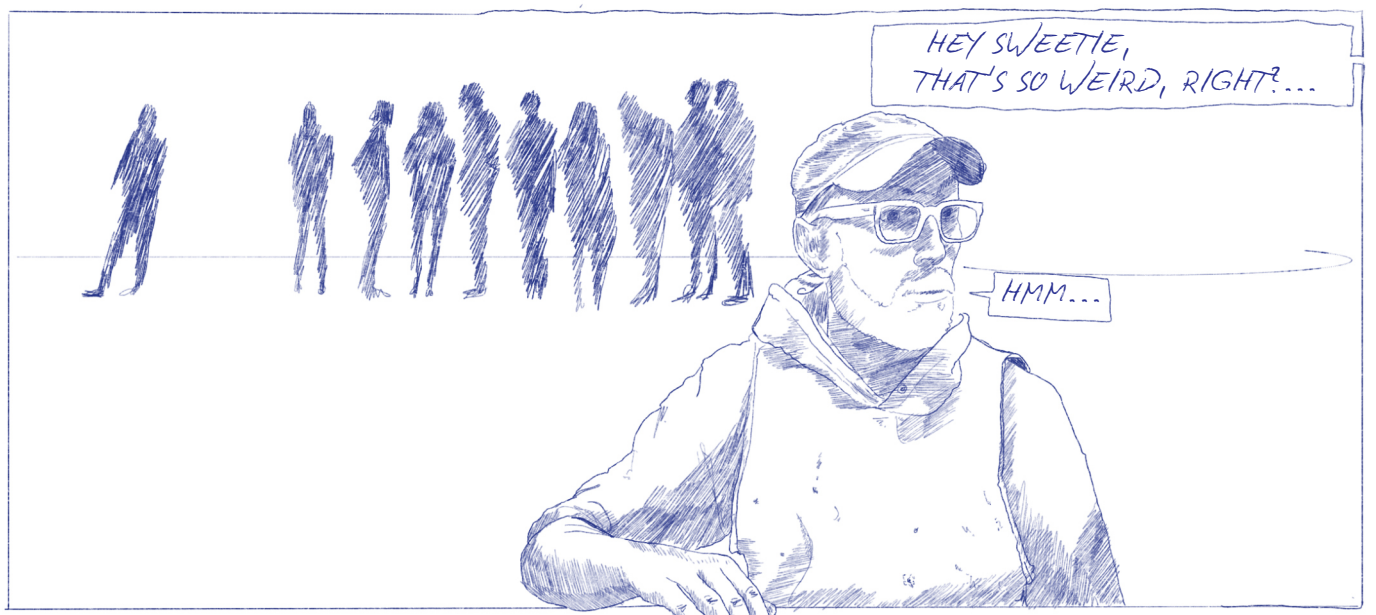
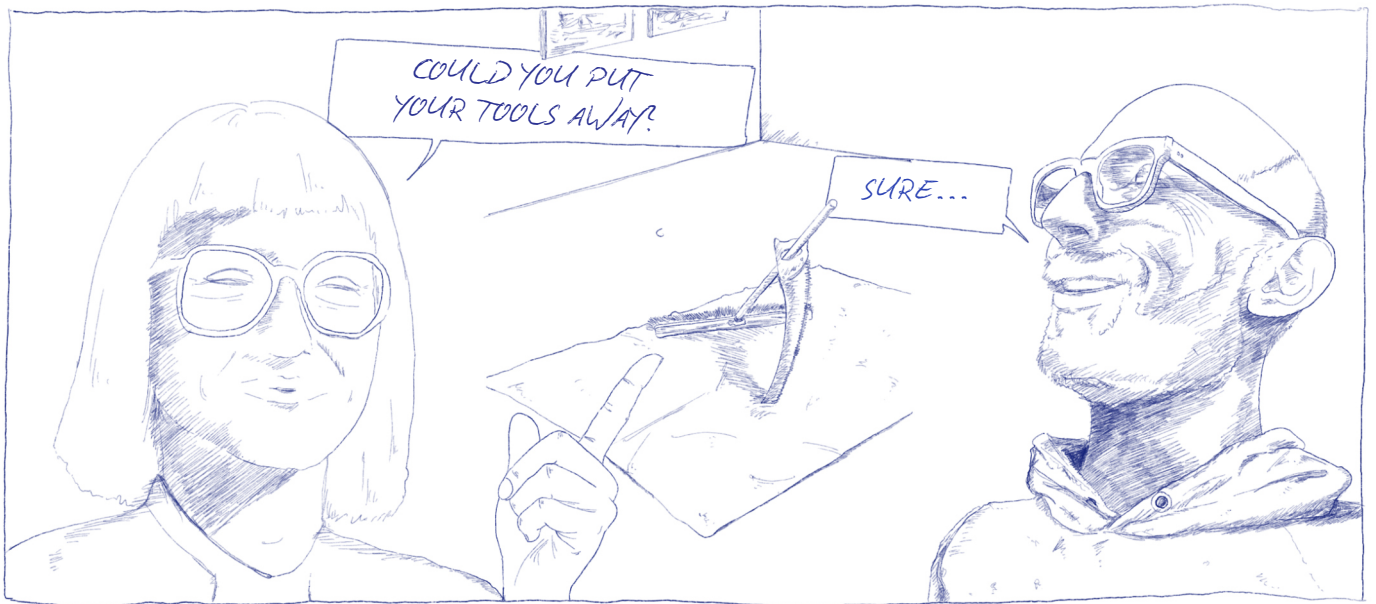

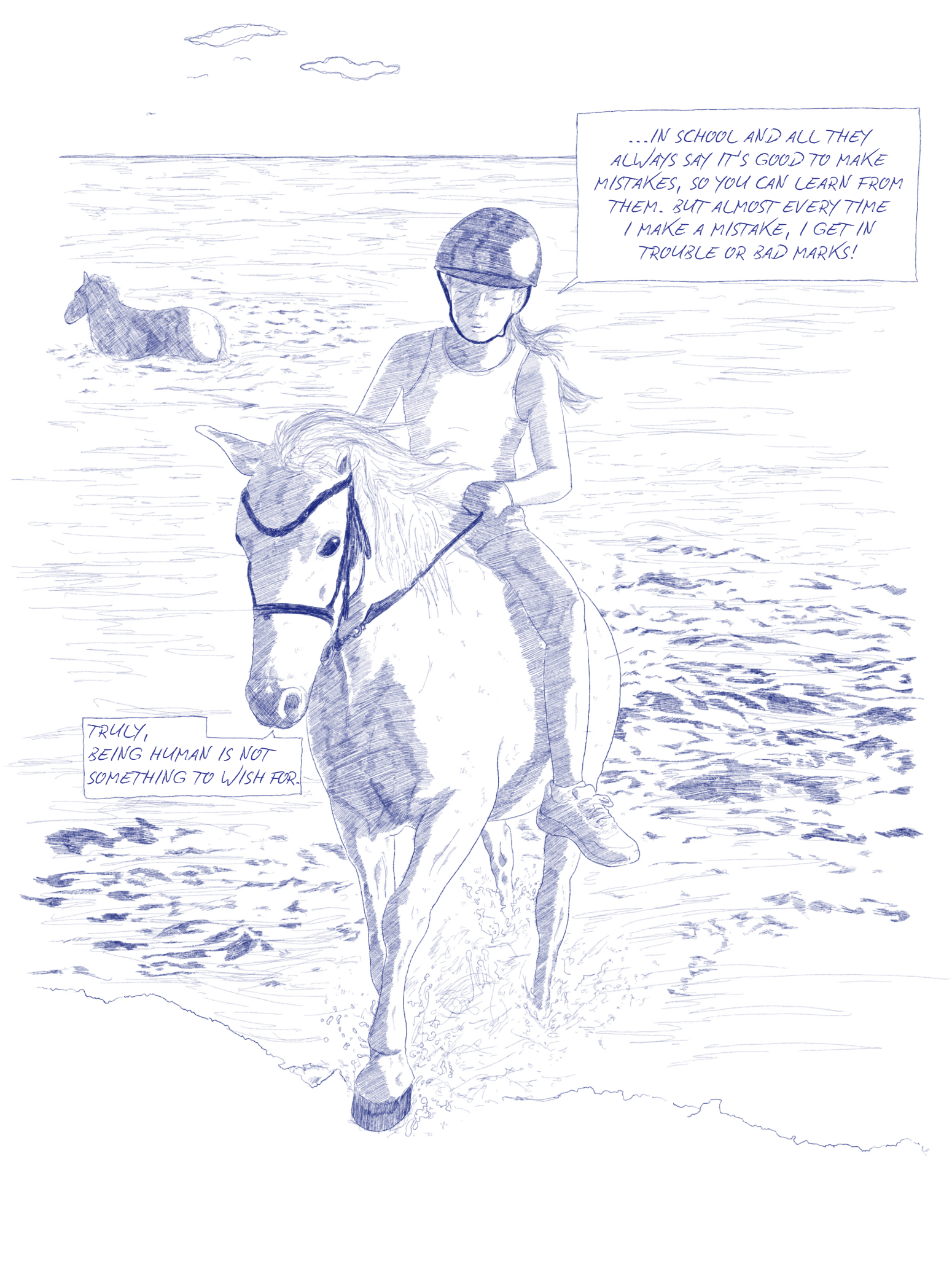

...IN SCHOOL AND ALL THEY ALWAYS SAY IT'S GOOD TO MAKE MISTAKES, SO YOU CAN LEARN FROM THEM. BUT ALMOST EVERY TIME I MAKE A MISTAKE, I GET IN TROUBLE OR BAD MARKS!

TRULY,
BEING HUMAN IS NOT
SOMETHING TO WISH FOR.

SO DAD,
WHAT ARE YOU DOING?



I'M IN THE STUDIO,
TELLING THE STORY
ABOUT THE PICTURE.



OH, THAT
ONE.



WHERE WAS I. OH RIGHT!

YOUR PROBABLY WONDERING
HOW I GOT THE PICTURE INTO THE MUSEUM.
THERE WAS A BEAUTIFUL MISPRINT FOR ANOTHER
EXHIBITION, THAT WAS SUPPOSED
TO BE THROWN OUT.

I PAINTED IT OVER RIGHT THERE.

SO I DIDN'T HAVE TO SNEAK
ANYTHING INTO THE MUSEUM.



NIGHT AT THE MUSEUM.

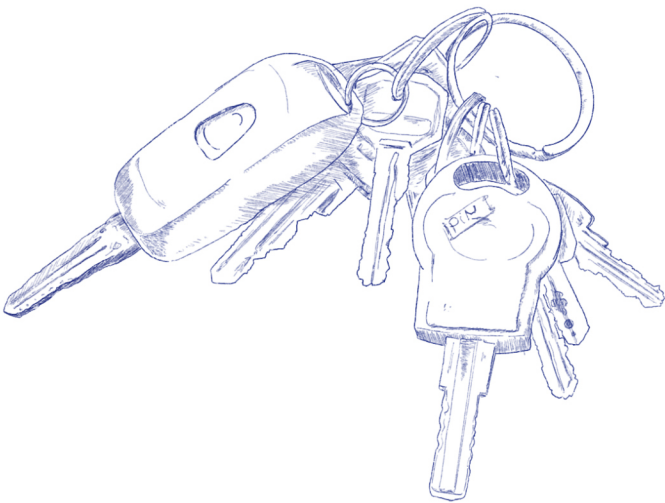
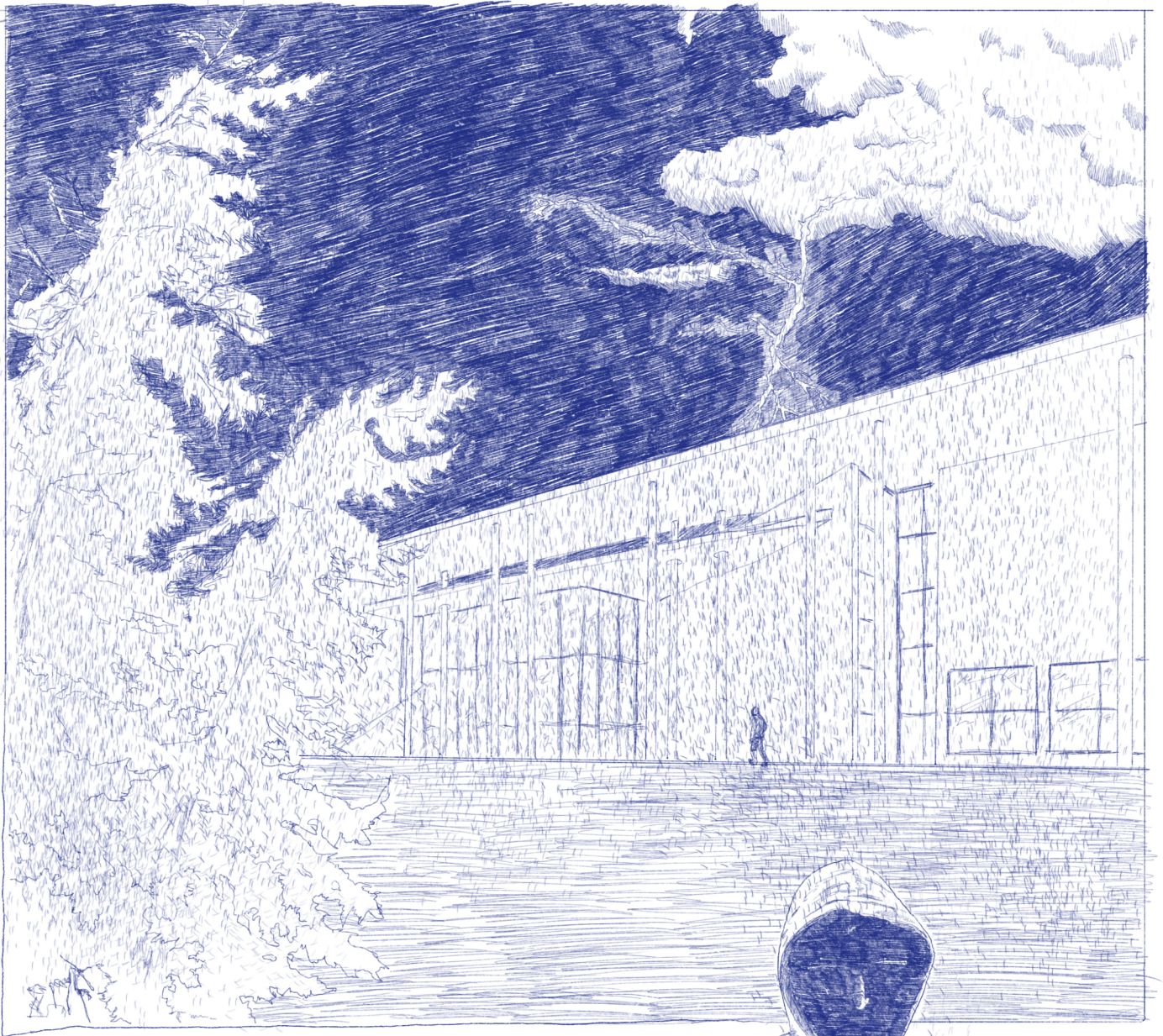

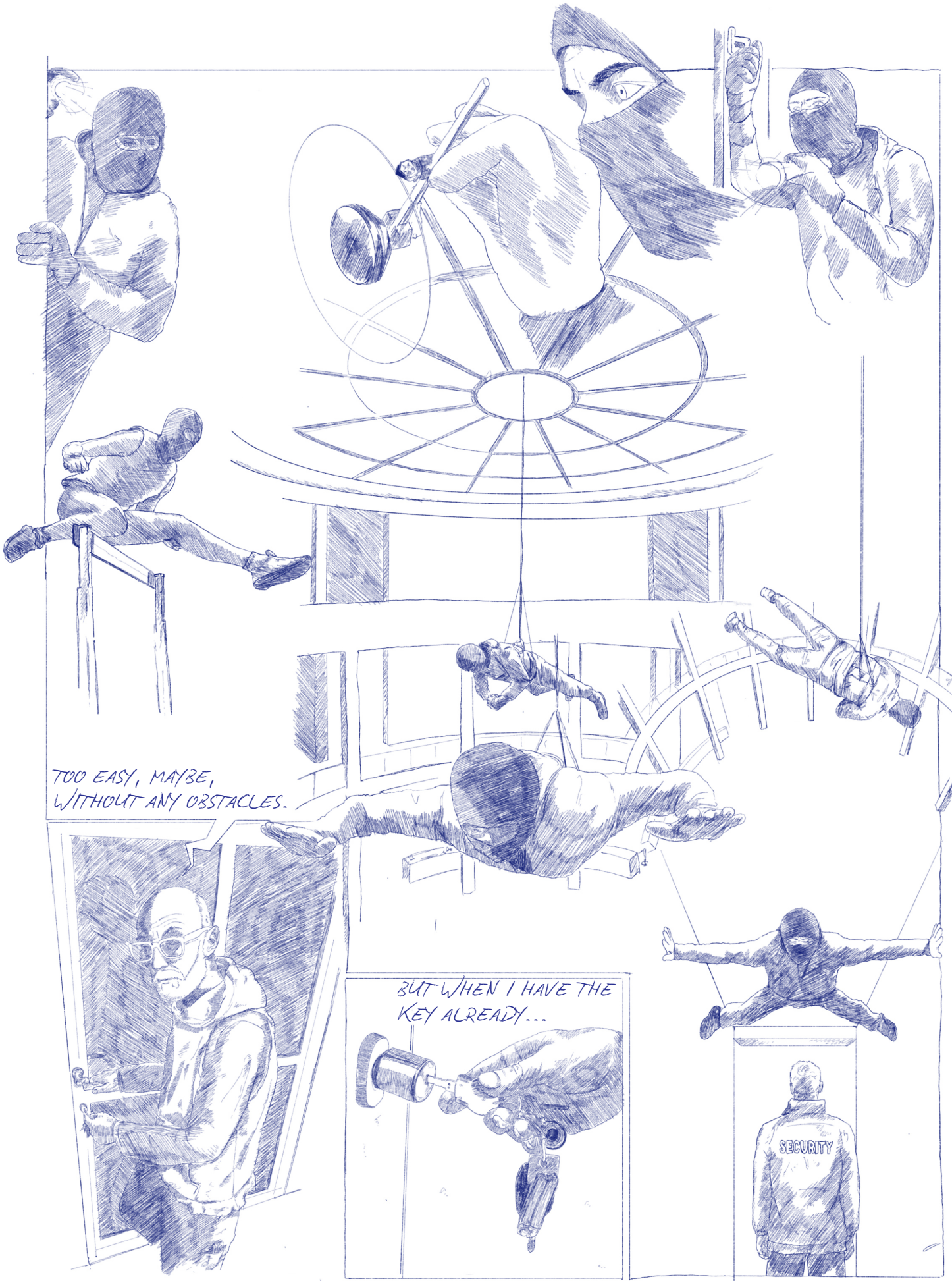

TOO EASY, MAYBE,
WITHOUT ANY OBSTACLES.

BUT WHEN I HAVE THE
KEY ALREADY...



NICE, WITHOUT ANY SPECTATORS.



I'M ACTUALLY A BIT EXCITED.



"innocents whistling"



"more innocent whistling"



WELL, UNFORTUNATELY I'VE BEEN BANNED FROM TALKING ABOUT THE EXACT DETAILS OF HOW I PUT THE PICTURE UP ON THE WALL, SO YOU'LL HAVE TO SETTLE FOR A MANUAL.



TAVLA HÄNGA UPP

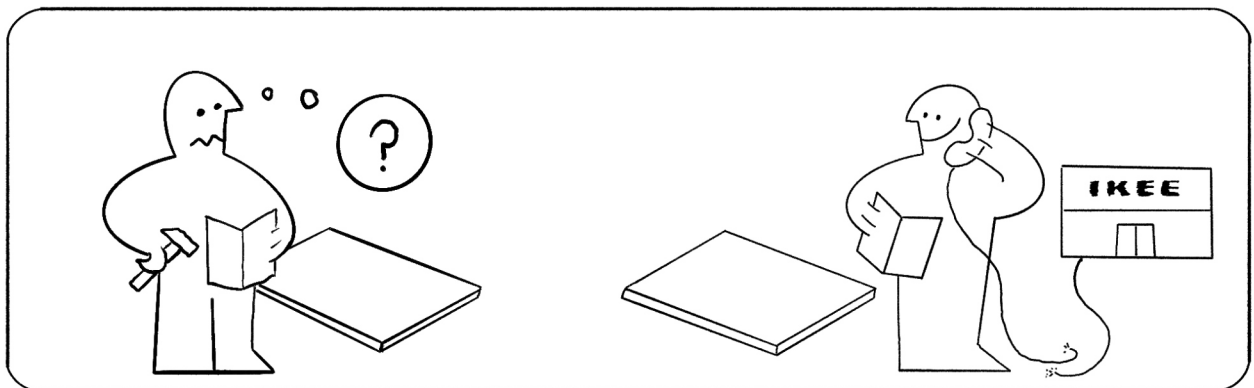
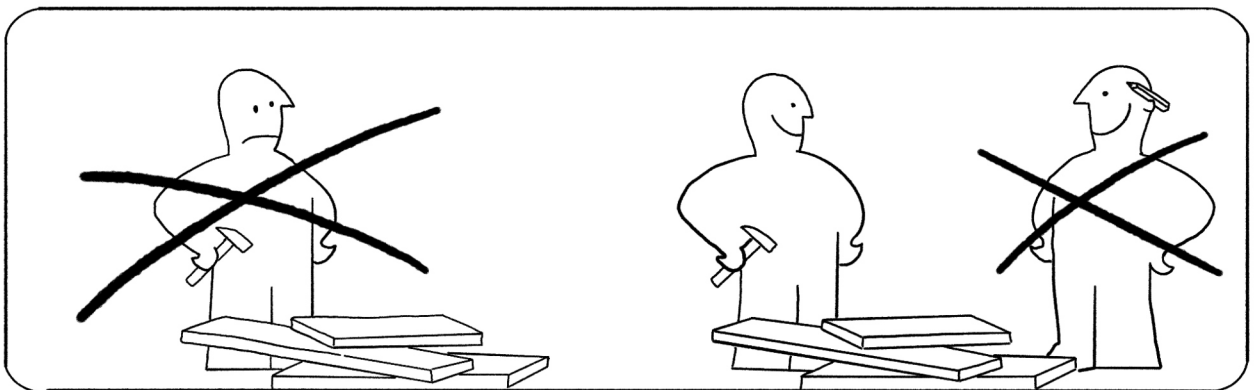
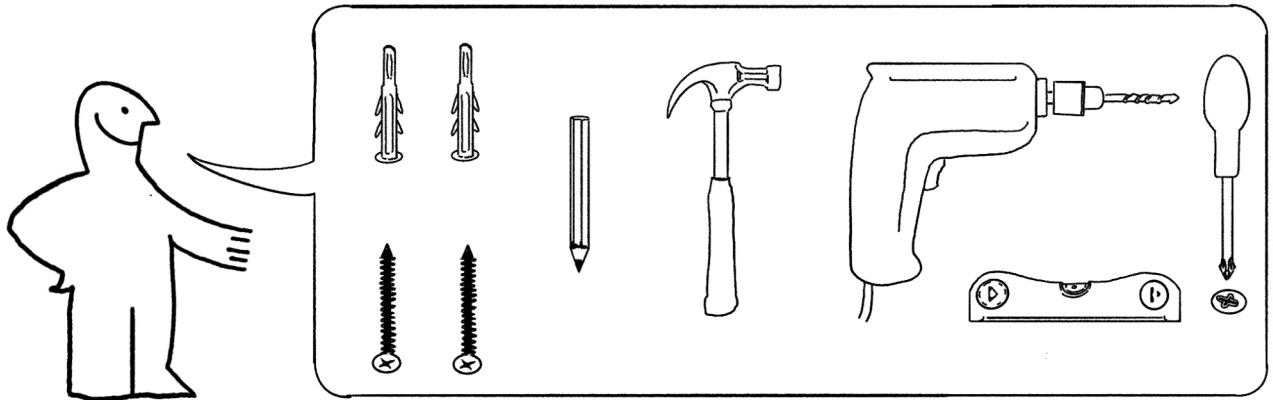

Caution: Each drilled hole costs € 100

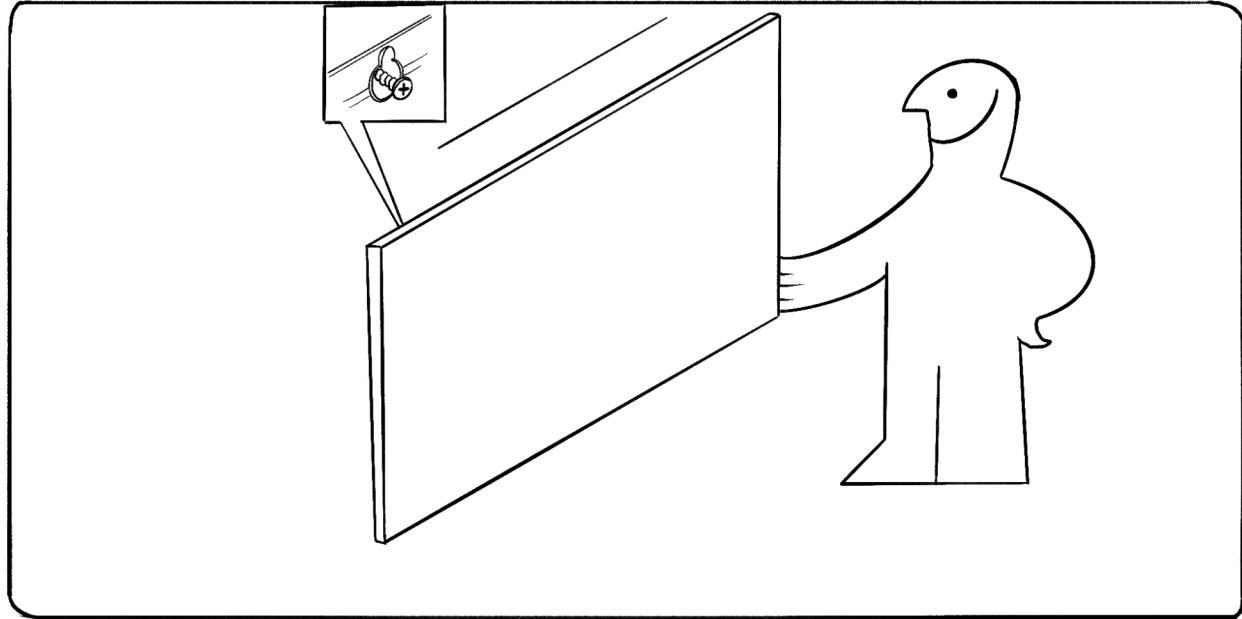
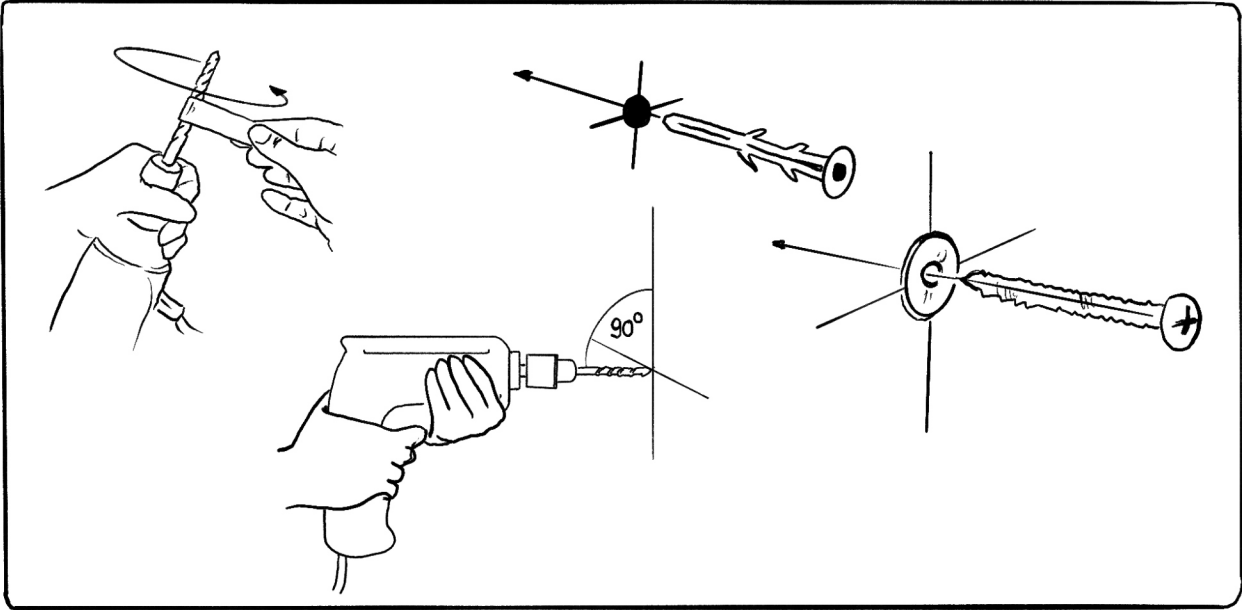
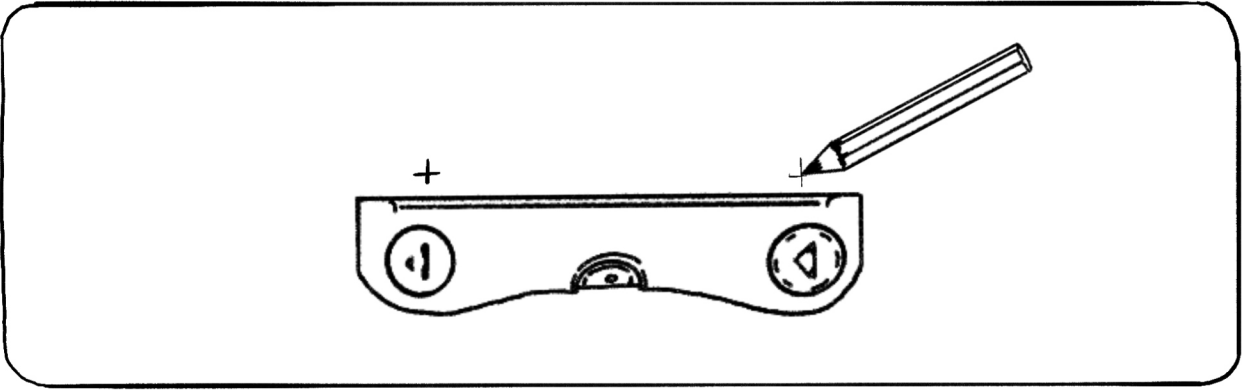

AND THEN IT WAS
ALREADY UP.



THE PAINTING



HEY, YOU KNOW I PUT THE PICTURE UP IN THE MORNING, NOT AT NIGHT, RIGHT?



IT'S MORE DRAMATIC AT NIGHT. REMINDS OF FRANKENSTEIN'S MONSTER, THE IDEA BORN IN A STORM.

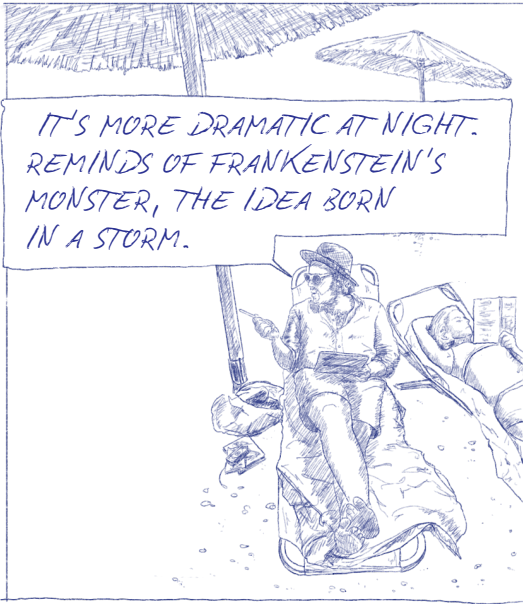

I SEE... AND THE KEY, ACTUALLY I HAD ONE OF THESE THINGS, YOU KNOW...



THE KEY IS A BETTER METAPHOR. FOR ART HISTORIANS TO RACK THEIR BRAINS ABOUT IT.



NICE IDEA! LET'S TALK ABOUT THE COVER ONCE MORE.

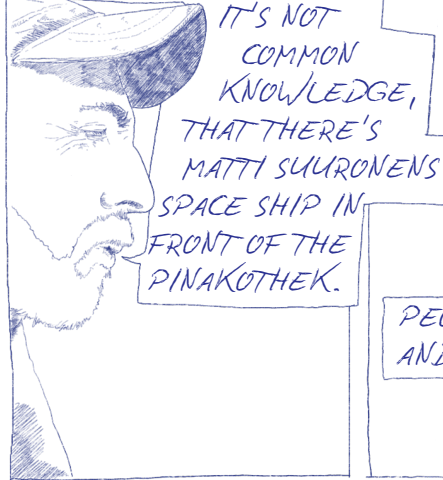

IT'S NOT COMMON KNOWLEDGE, THAT THERE'S MATTI SUURONENS SPACE SHIP IN FRONT OF THE PINAKOTHEK.

PEOPLE ARE INTO UFOS AND ALIENS...



OK, SO I CAN TELL EVERYONE, YOU'RE WILDLY OVERPLAYING. AND I'M OFF THE HOOK!



SOUNDS GOOD!

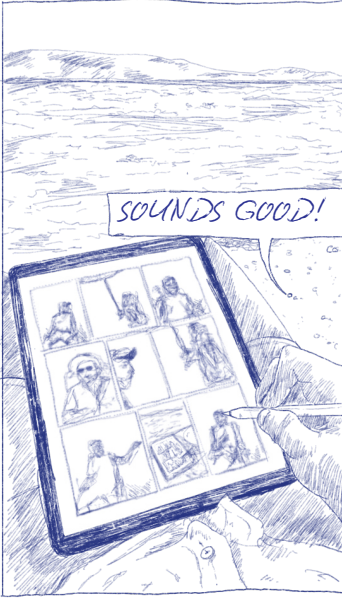

YEAH, AND THEN THE GLITCH BEGAN!

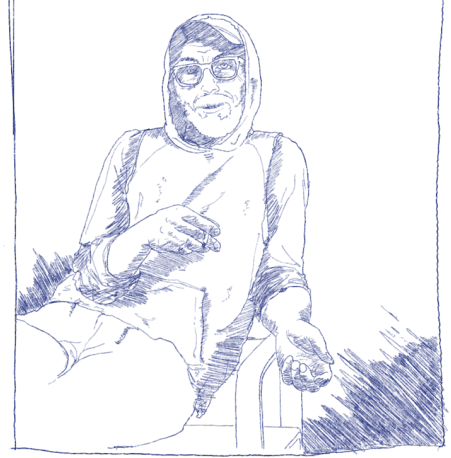

WHO DO YOU ACTUALLY ADDRESS WHEN YOU HAVE A POSITIVE REACTION TO A PICTURE?

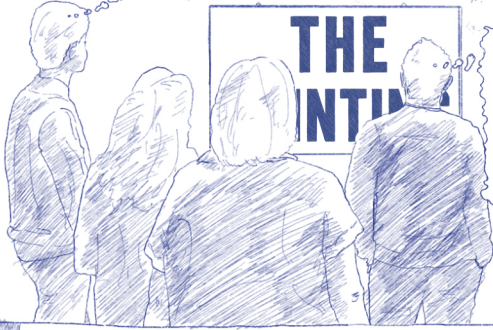

THE AESTHETIC EXPERIENCE EVOKED BY THE ARTIST IS AN INVITATION!

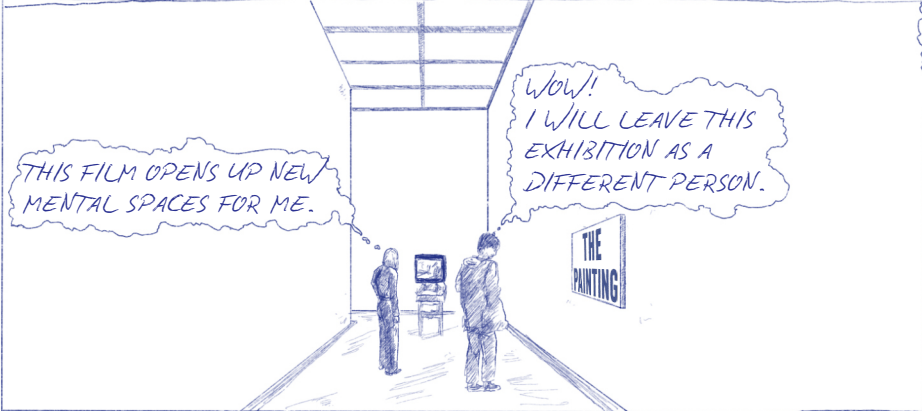

THIS FILM OPENS UP NEW MENTAL SPACES FOR ME.

Wow! I WILL LEAVE THIS EXHIBITION AS A DIFFERENT PERSON.

HERE I CAN TRACE GLOBAL PHENOMENA.

PRETTY GREAT!

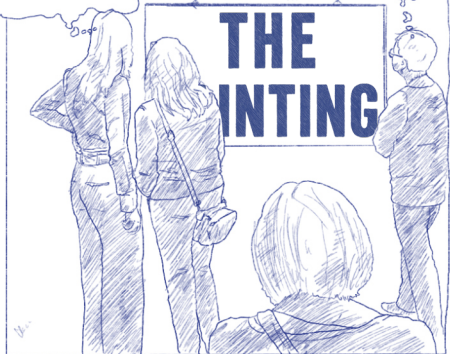

I'M SO UNDERPAID...



HUH...



HAS THAT BEEN HERE BEFORE?



SUPERVISOR!
SUPERVISOR!

HOW DID I
GET HERE?

MIT VOLLER
STÄRKE ANZU-
TANZEN?

SICHER MACHEN
WIR DAS.

= **RELIANCE** IN AT FULL
STRENGTH? WE DO IT SAFE.

ISN'T EVERYONE
AN ARTIST IF THEY
CAN HOLD A BRUSH?

OH...
THEY CALLED
THE POLICE?

POLIZEI

POLIZEI

POLIZEI

POLIZEI

THE
PAINTING





SOMETHING HAPPENED? DID SOMEONE NICK A PICTURE?

NO NO, HE ACTUALLY ADDED ONE!

POLIZEI



WELL THEN, I HOPE YOU FIND THAT SCALLYWAG.

THANK YOU, I DON'T REALLY CARE, DIDN'T DO NO HARM.

RESPONSIBILITY

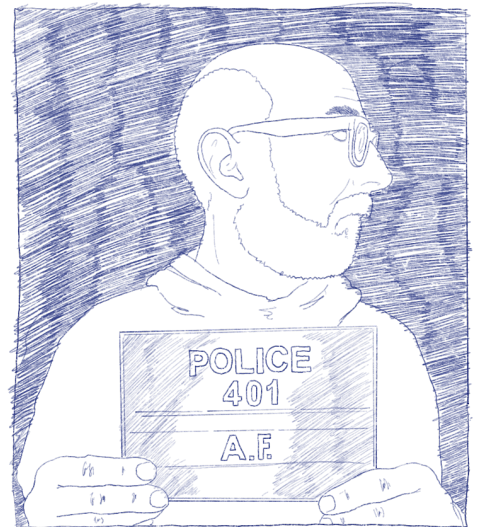
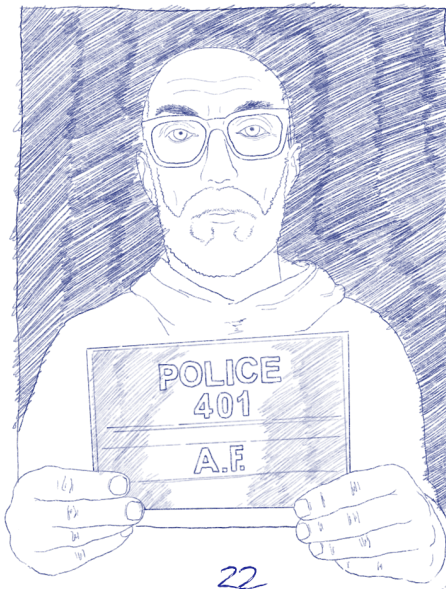
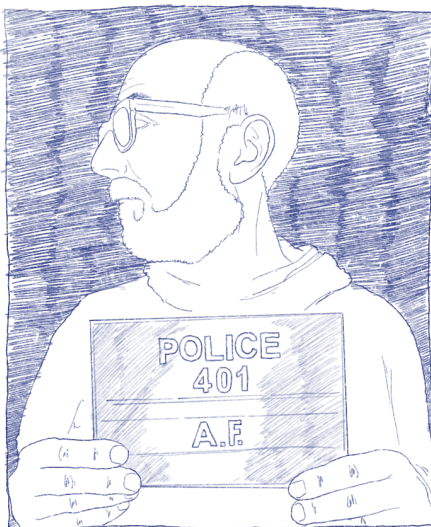
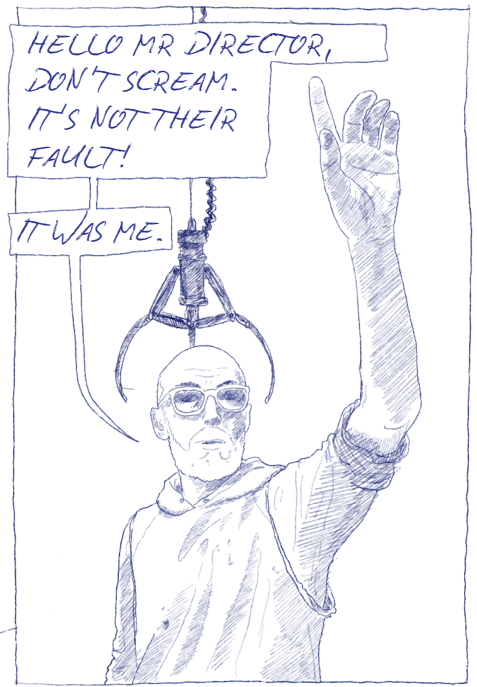
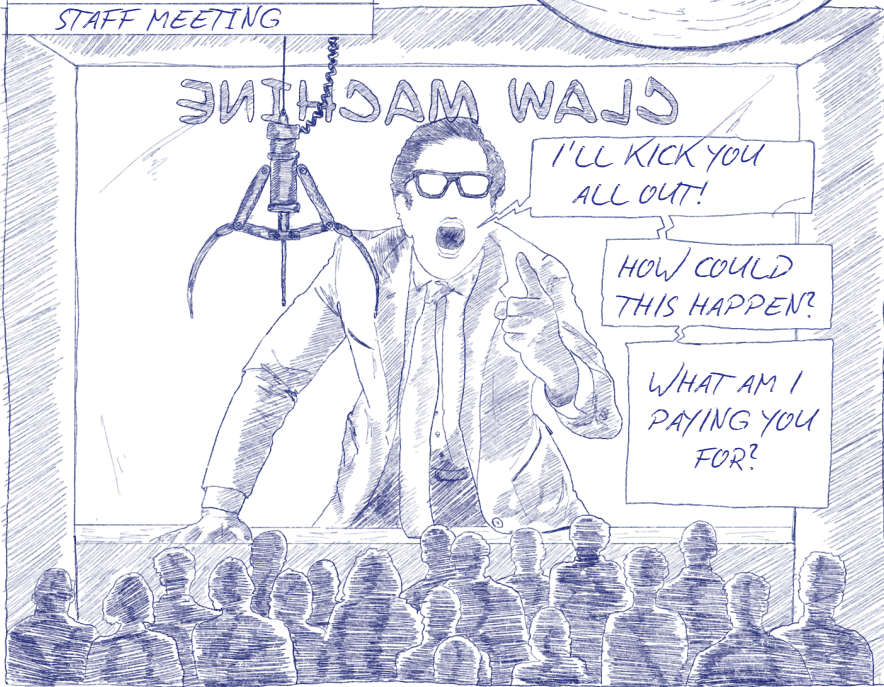

PERSONNEL OFFICE

SO, MR FAMILLER, I H
[REDACTED]
[REDACTED] WE
[REDACTED] EXACTLY [REDACTED]
[REDACTED]

[REDACTED] JUST WANTED [REDACTED]
[REDACTED]
SHOW WA [REDACTED]
[REDACTED]
[REDACTED]

[REDACTED]
[REDACTED]
[REDACTED] WER IST EIN MUSC [REDACTED] DAS
[REDACTED] AYO

[REDACTED]
[REDACTED]
[REDACTED]

WHAT KIND OF TRIP IS THIS?

[REDACTED] WISSETT'S
[REDACTED] COOPERATE,
[REDACTED] AND
[REDACTED] COOPERATE,
[REDACTED]



ISN'T THAT A LITTLE OVER THE TOP?

[REDACTED] FROM YOUR
[REDACTED] WOULD BE GOOD
ANNULMENT CONTRACT [REDACTED]

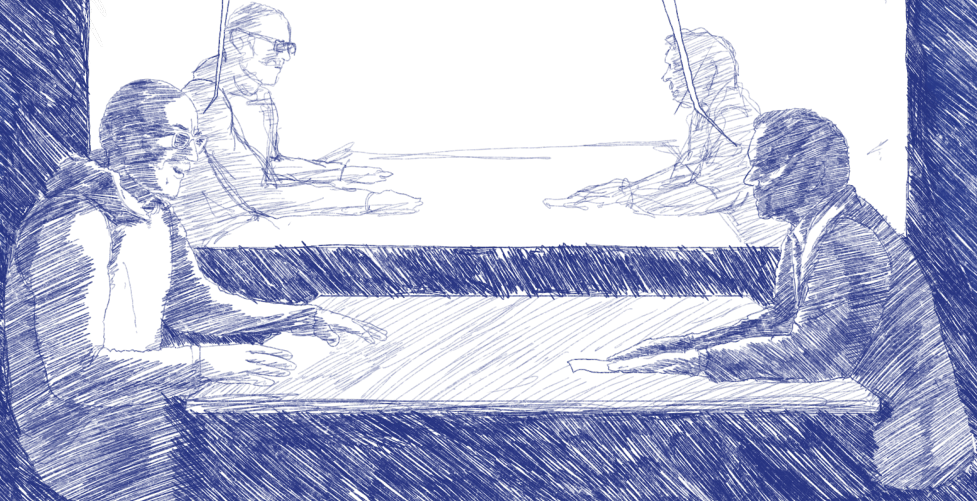

[REDACTED] TERMINATION AGREEMENT
[REDACTED]
[REDACTED] AND [REDACTED] GO
[REDACTED] ALONG WITH.

DON'T MAKE IT SO HARD FOR YOURSELF...
THINK OF YOUR FAMILY.



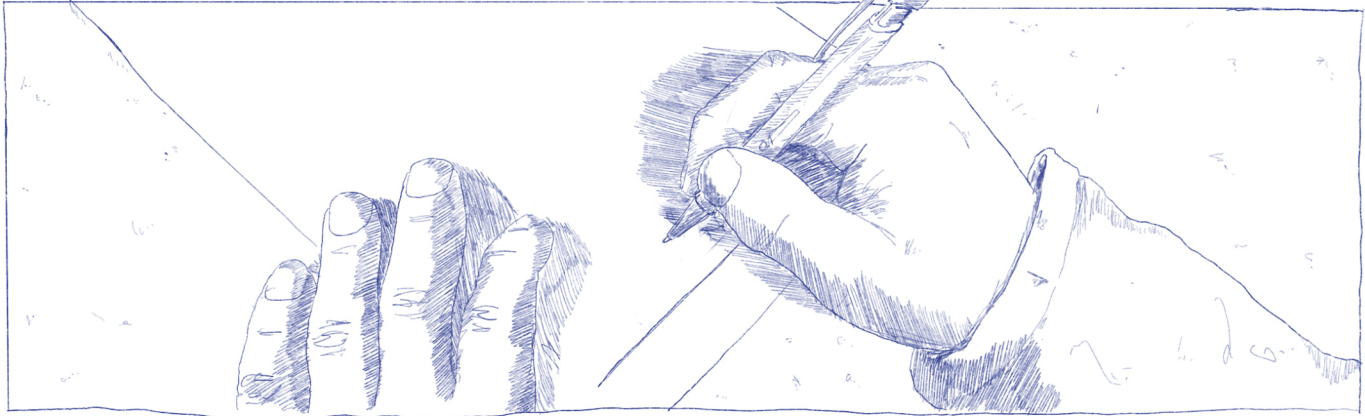
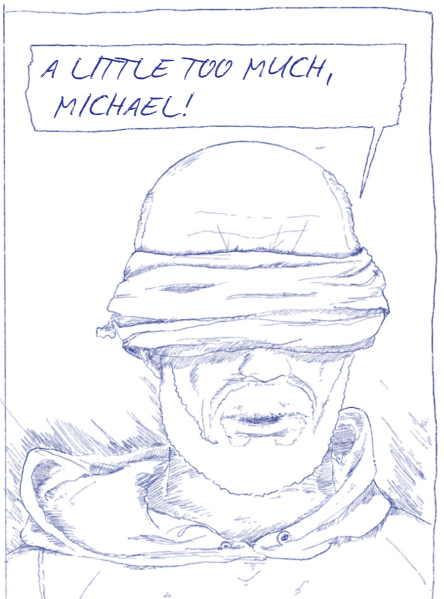

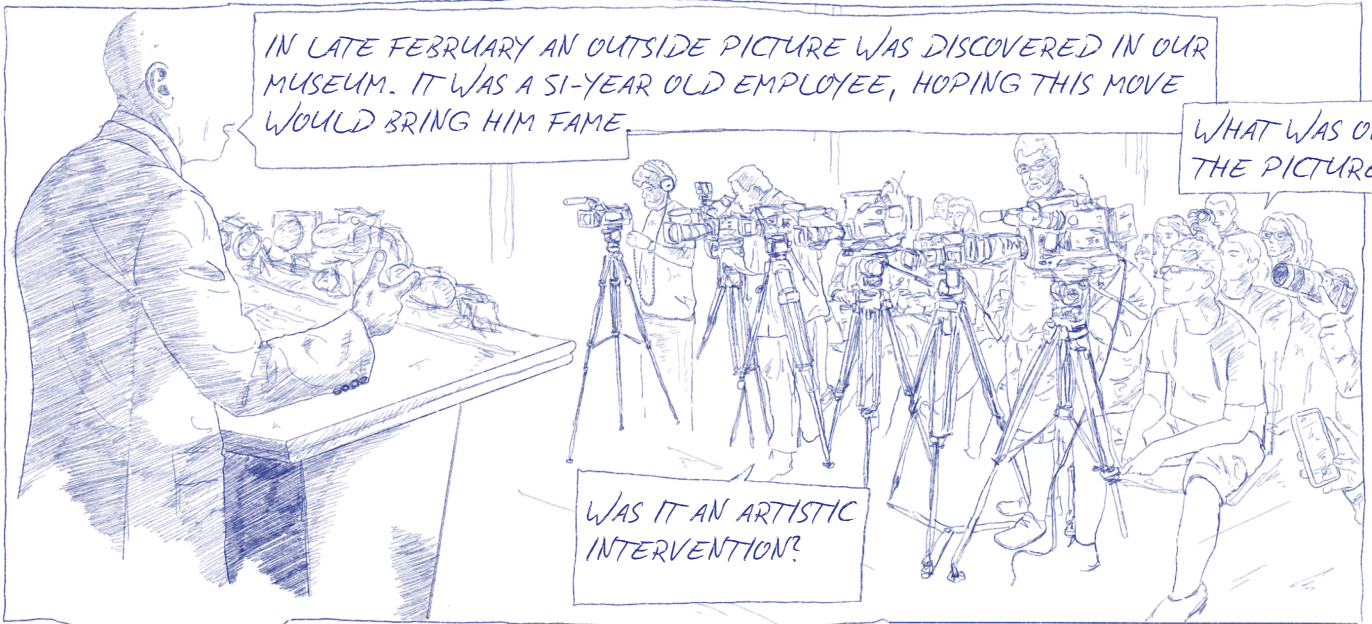

IN LATE FEBRUARY AN OUTSIDE PICTURE WAS DISCOVERED IN OUR MUSEUM. IT WAS A 51-YEAR OLD EMPLOYEE, HOPING THIS MOVE WOULD BRING HIM FAME.

WHAT WAS ON THE PICTURE?

WAS IT AN ARTISTIC INTERVENTION?

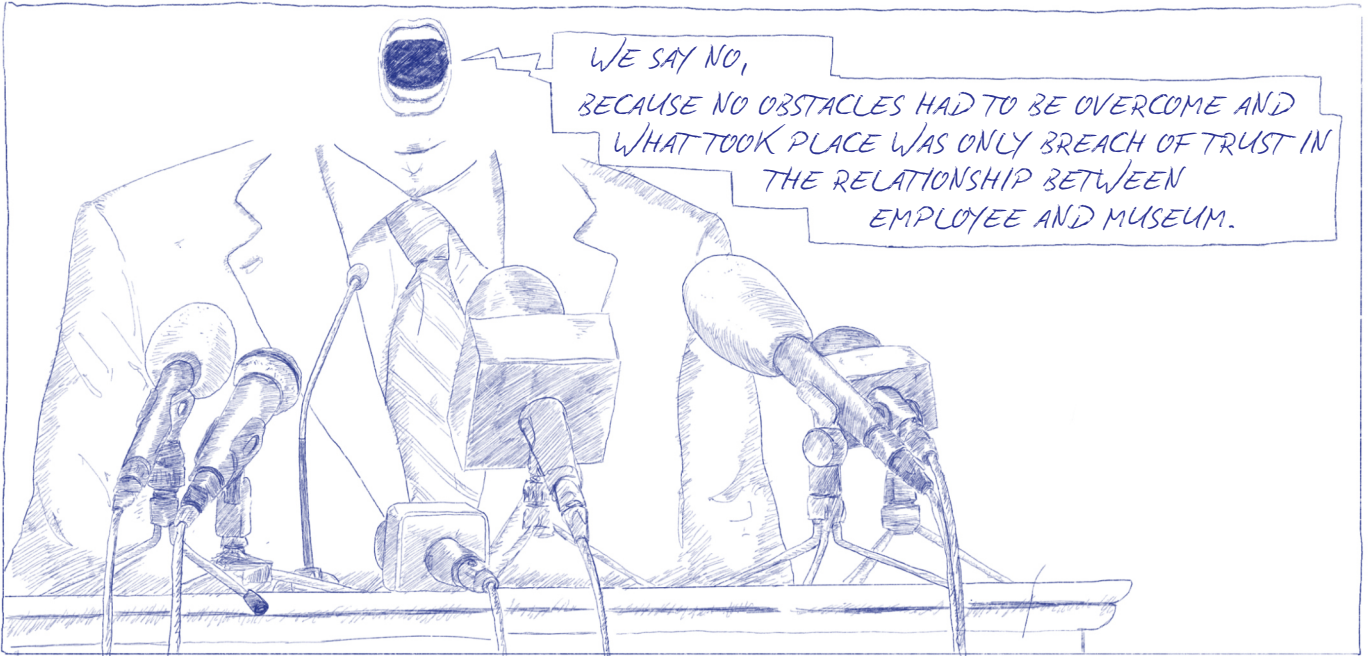

WE SAY NO, BECAUSE NO OBSTACLES HAD TO BE OVERCOME AND WHAT TOOK PLACE WAS ONLY BREACH OF TRUST IN THE RELATIONSHIP BETWEEN EMPLOYEE AND MUSEUM.

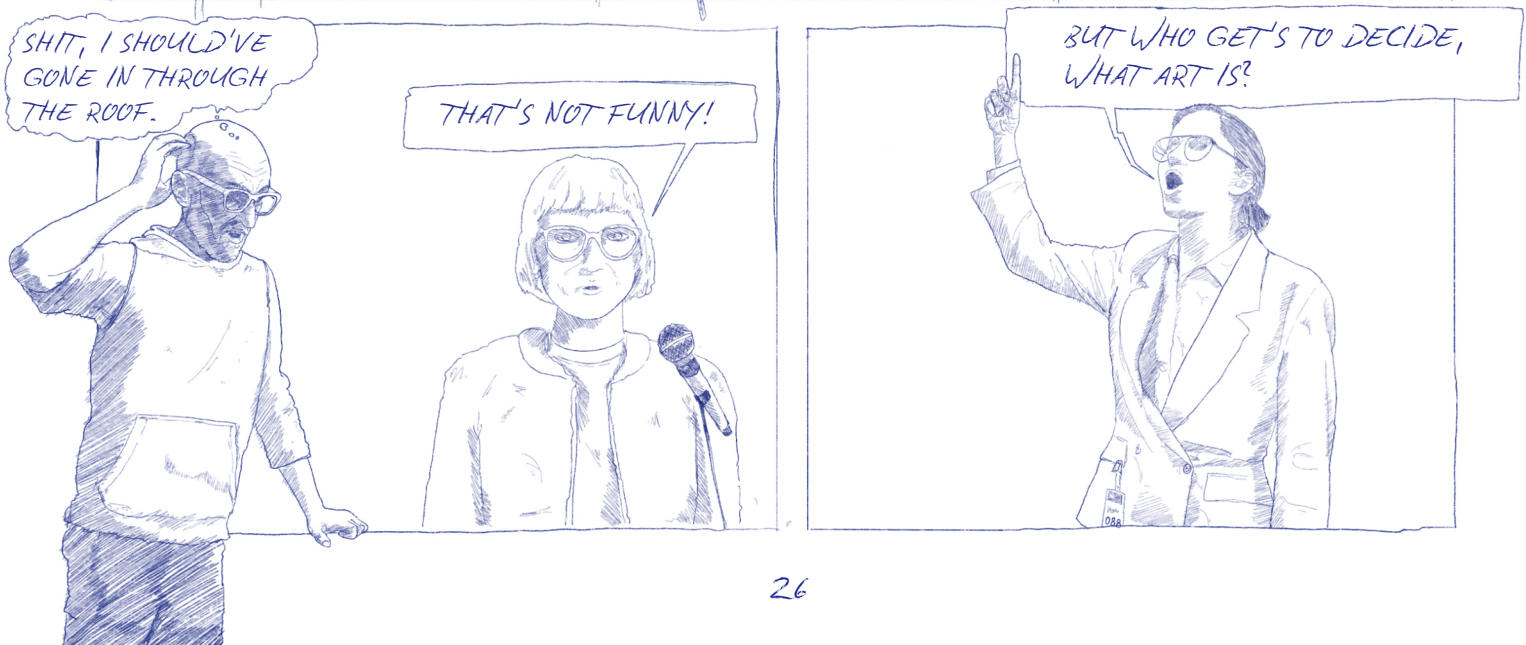

SHIT, I SHOULD'VE GONE IN THROUGH THE ROOF.

THAT'S NOT FUNNY!

BUT WHO GET'S TO DECIDE, WHAT ART IS?

Süddeutsche Zeitung April 8 2024,

Employee wants to be Famous - Sneaks his own Painting into Museum

The 51-year-old man worked in technical service, calls himself freelancing artist. He had access to exhibition spaces outside of opening hours and did not attract any attention while hanging the picture.

Now the police investigates - though for a rather minor offence, criminal property damage, as the man drilled two holes into an empty wall in a passageway. He cannot be accused of any other prosecutable action. Nevertheless, there are consequences to the man's action: He received hous ban, was laid off; the employment was terminated by cancellation agreement.

THE SELF-PROCLAIMED JOURNALIST MADE A BAD MISTAKE HERE!

ONE BECOMES AN ARTIST WHEN DESIGNATING ONESELF AS SUCH.

WITH ASSHOLES, IT'S THE OPPOSITE.

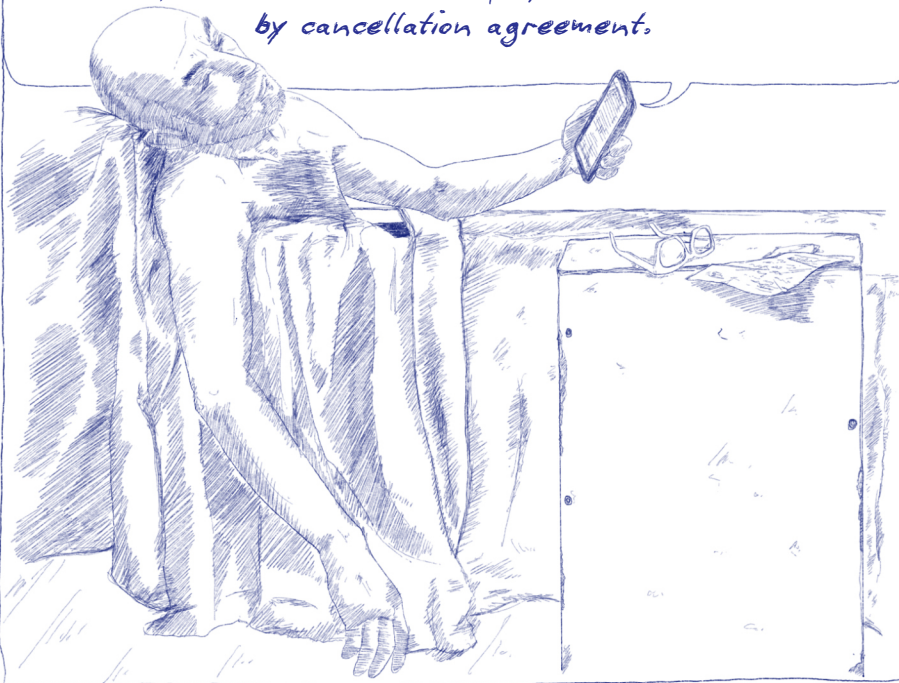

THANKS MARCEL, BUT WOULD YOU MIND SITTING DOWN TO PISS, PLEASE?

HOW IS IT MY FAULT YOU CAN'T AFFORD A URINAL?

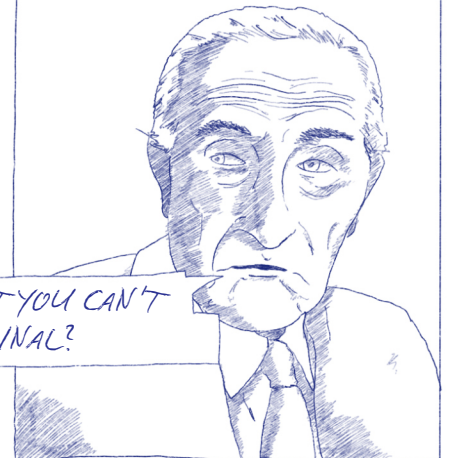

The Washington Post
Democracy Dies in Darkness

Museum fires employee for hanging up his own artwork

Employers love a self-starter - but when a worker with lofty ambitions decided to mount his own piece at an art museum in Munich this year, his efforts were not appreciated by his superiors.

The Guardian

German art museum fires worker for hanging his own painting in gallery

Staff member put work on display at Munich's Pinakothek der Moderne in hope of achieving his breakthrough

According to a quote commonly - if wrongly - attributed to the artist Andy Warhol, everyone will have their 15 minutes of fame. At Munich's Pinakothek der Moderne museum earlier this year, one technician and aspiring artist got to bask in the limelight for a whole eight hours.

BBC
German gallery fires employee for hanging own art in exhibition

The museum in southern Germany on Tuesday confirmed that it had fired a member of its technical services team after he was found to have hung one of his own paintings in a part of the gallery dedicated to modern and contemporary art, allowing him to share a space with works by pop art pioneer Warhol for an entire day.

CNN

German museum worker fired after hanging his own art in gallery (CNN) — For a brief moment, one German man achieved his dream: his artwork hanging in a famous museum.

BOOM

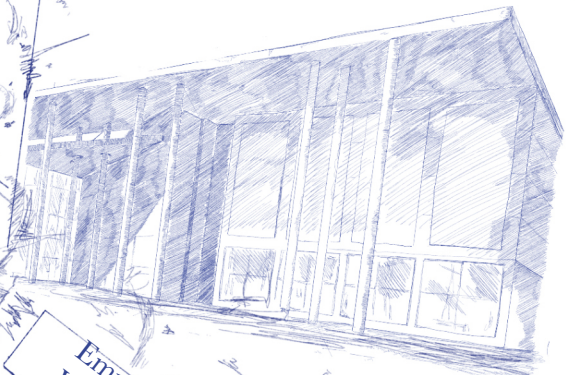

Smithsonian MAGAZINE
Employee Quietly Sneaks His Own Painting Onto the Walls of a German Museum

For most aspiring artists, getting work onto the walls of prominent museums takes time, patience and talent. But for one German museum employee, all it took was a few screws.

IT'S CRAZY, EVERYONE IS JUST COPYING EACH OTHER.
THAT'S THE REALITY OF THE MEDIA.



But can you blame him? If you were an artists, would you reproach him for trying?

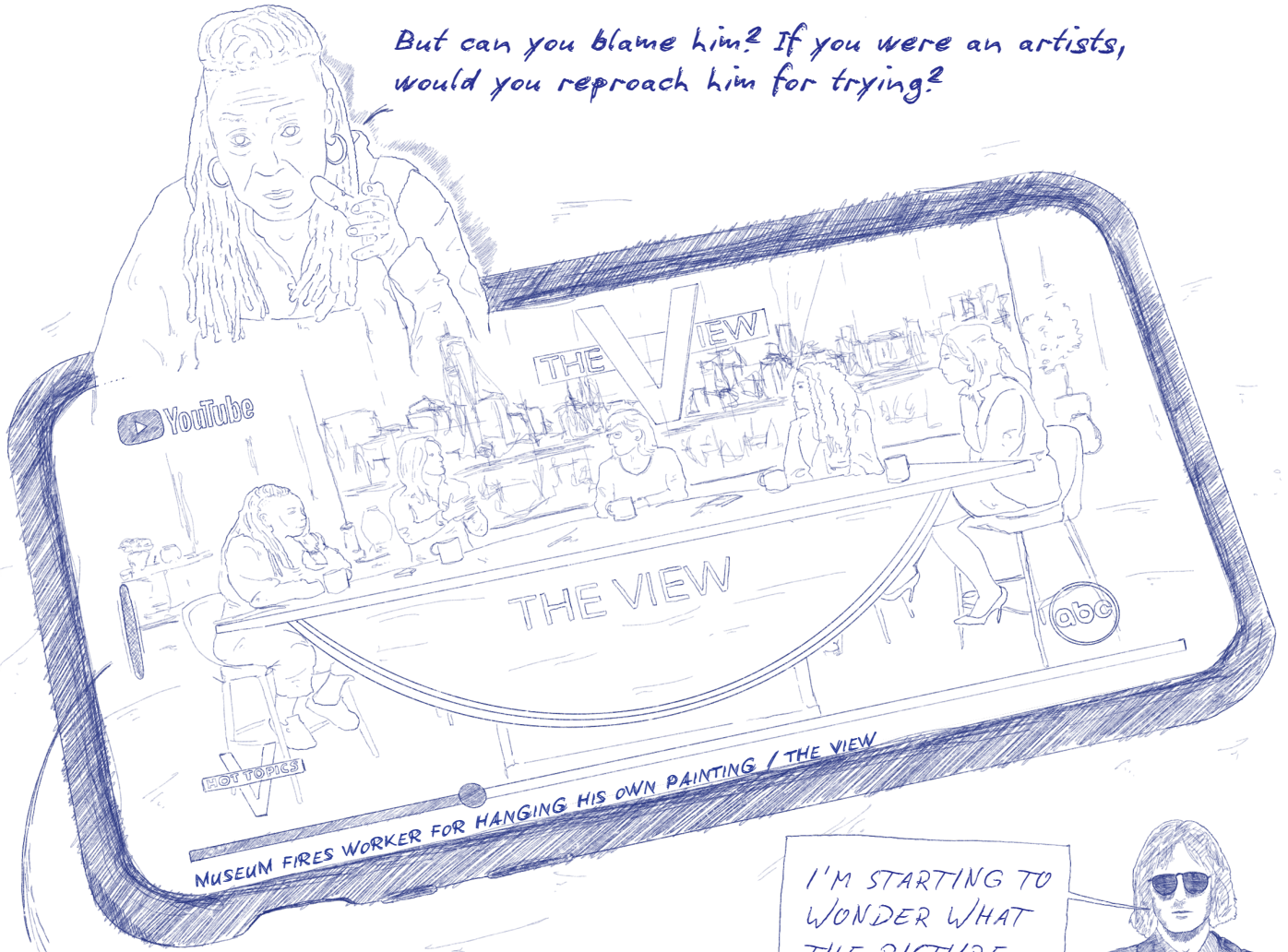

No, I think it's awesome. I love it, 'cause we know how hard it is for artists to get appreciation for their work. Many don't know that Banksy did the same thing. He put up his works in different museums. He said, he just put them up in a gallery - otherwise they would just be sitting at home and no one would see them.

[audience laughs]

I want justice for this guy, give him back his job. I like his drive.

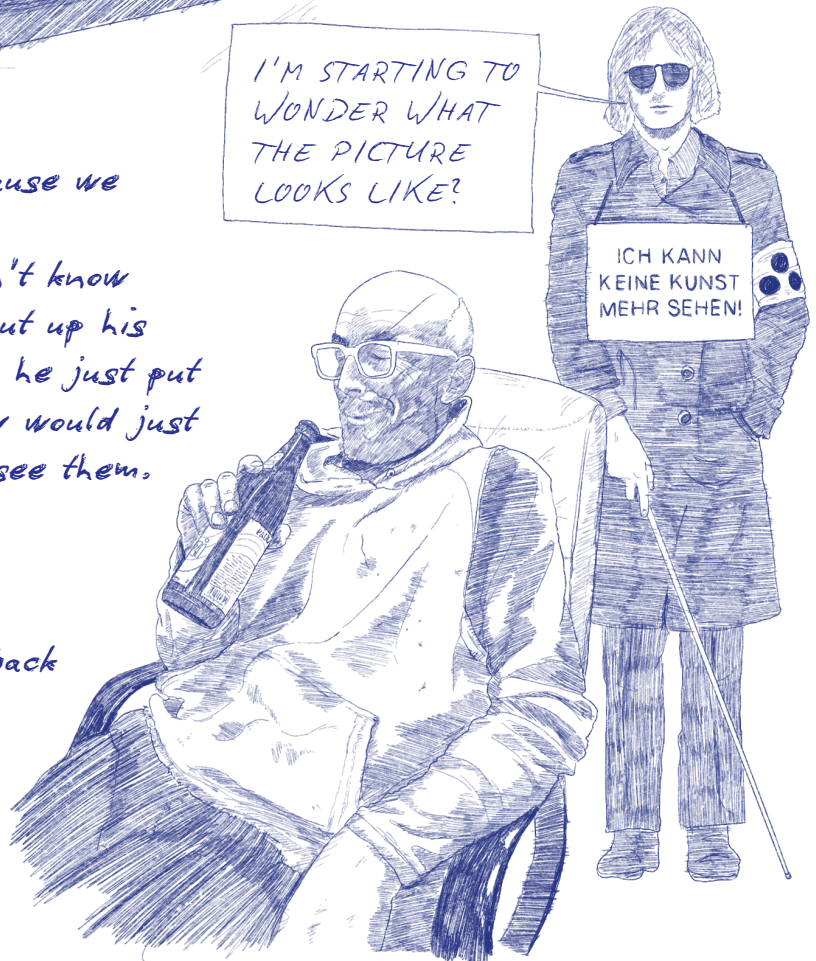

HEY, AFTER ALL THOSE 'AMATEUR ARTIST' NEWS AND 'STRIVING-FOR-FAME' SHIT.

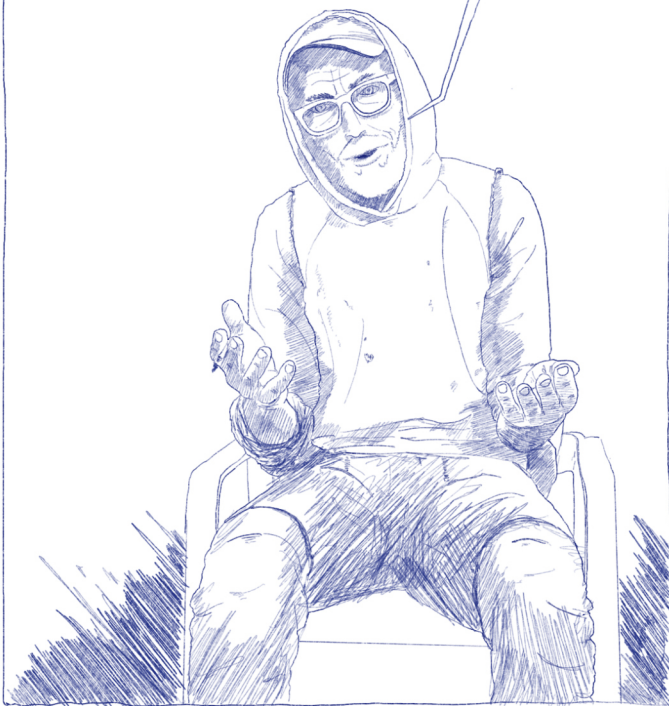

THERE WAS A REALLY NICE STORY IN THE GUARDIAN.

THEY ACTUALLY DID SOME RESEARCH AND THE PICTURE WAS SHOWN.

YOU SHOULD READ IT!



THEN THE AMERICANS TURNED THE STUNT INTO SOME ROBIN HOOD STORY.

THEY LIKE THIS KIND OF STUFF!



AND GUESS WHAT, FINALLY THERE WAS AN ARTICLE BY THE BAYRISCHER RUNDFUNK.



BR

85%

Employee Picture in Pinakothek: An Art Campaign after all?

This case was covered by media, globally. An employee hung his own painting in the Pinakothek der Moderne and was subsequently laid off. New details are raising the question: Was it an art campaign after all?

Suddenly there was an additional work in the exhibition. There goes the unplanned disruption! A double sense picture error. According to Bayrischer Rundfunk2 research the paintings base material itself was - mind you: A misprint! Originally made for another exhibition in the Pinakothek, the print was showing a family portrait. Faces and background were covered with white paint by the 51-years-old, so only the clothes of the four family members remain visible.

Image distortion with white paint. A glitch. Was the employee actually inspired by the exhibition title, was he intentionally commenting the "art of distortion"? Did he want to explore the museums institutional reaction to an error in the system and how seriously the much proclaimed message of their own exhibition would be taken?

YEAH, THAT WAS ABOUT IT. WE'VE REACHED THE END, THERE'S NOT MUCH MORE TO TELL. BUT IF YOU EXPECTED A COSY HOLLYWOOD HAPPY END, YOU'RE WRONG. EVERY NEW DAY REMAINS CHALLENGING AND CHAOTIC. IN THE END, IT PUT ME BACK 200 EUROS AND ONE OF MY JOBS. MY DAUGHTER WANTS RIDING LESSONS, I STILL HAVE OTHER JOBS AND AT THE SAME TIME I'M TRYING TO MAKE ART. THE BIG BREAKTHROUGH? WELL, THAT DIDN'T HAPPEN EITHER, OF COURSE. BUT CUTTING OFF ONES EAR WOULD'VE BEEN A LITTLE TOO MUCH, AT LEAST I HAD MY FUN.

SO I CONTINUE MAKING ART, LIKE SO MANY OTHERS. MAYBE SOMETHING WILL COME FROM IT, WITH SOME LUCK AND THE LITTLE FUSS ABOUT THE ACTION.

YOU KNOW HOW IT IS...



WELL SAID, MICHAEL, BUT I THINK YOU'RE PROJECTING SOMETHING ONTO ME.

DAD, DINNER IS READY!

WE'RE COMING.



COME, MICHAEL, YOU'RE INVITED!



...AND WHO KNOWS, MAYBE IN FIVE YEARS THERE'S ONE OF MY PICTURES IN THE BRANDHORST?



MEANWHILE AT THE MUSEUM

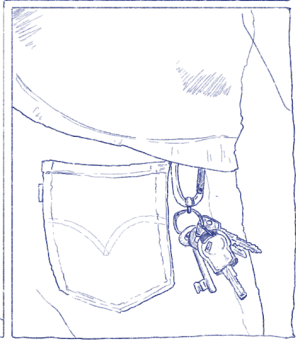
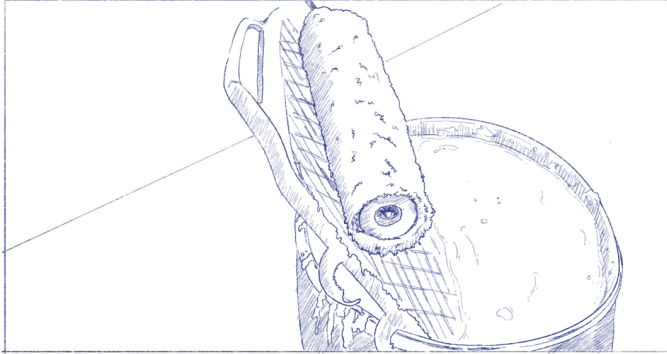
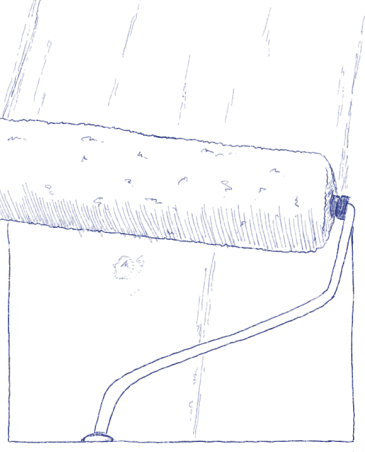
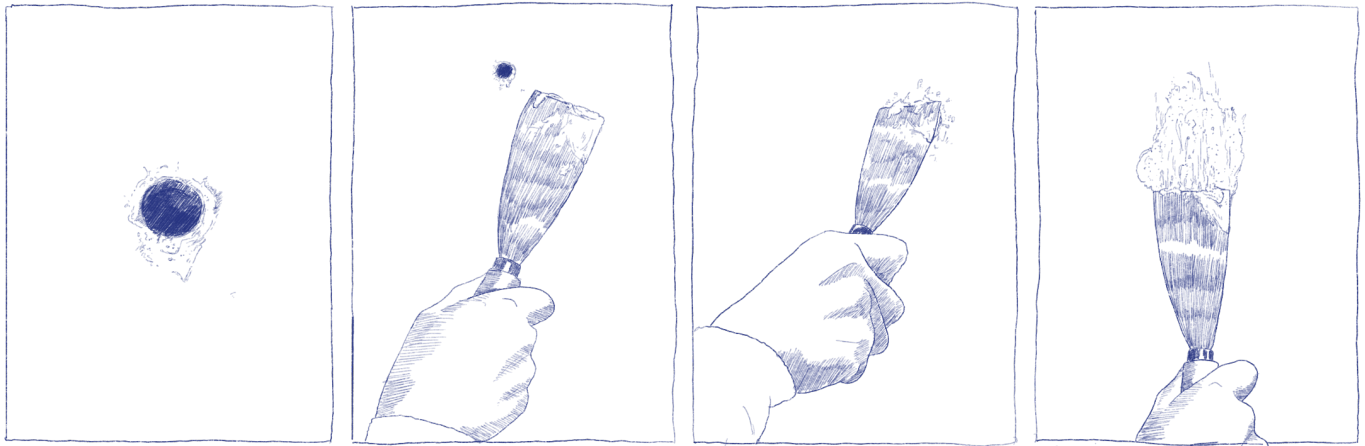

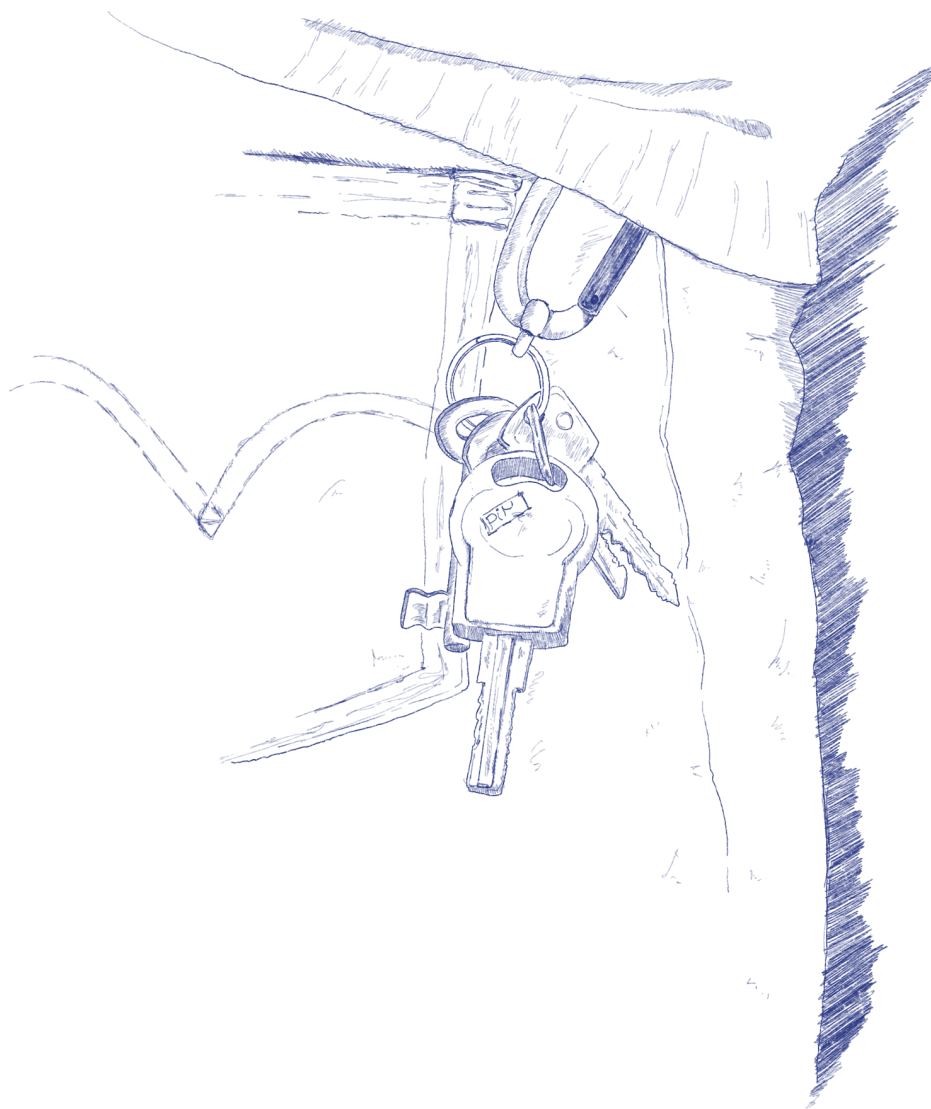

THANKS TO

Annelie Kleiner
Paul Valentin
Line Farniller
Milan Bettermann
Dr. Wolfgang Herrmann
Josef Schweigert omb2 Druckerei

&

Andrea Fraser
Marcel Duchamp
Timon Ulrichs

English translation by:
Caso Lin Schiml

Format C

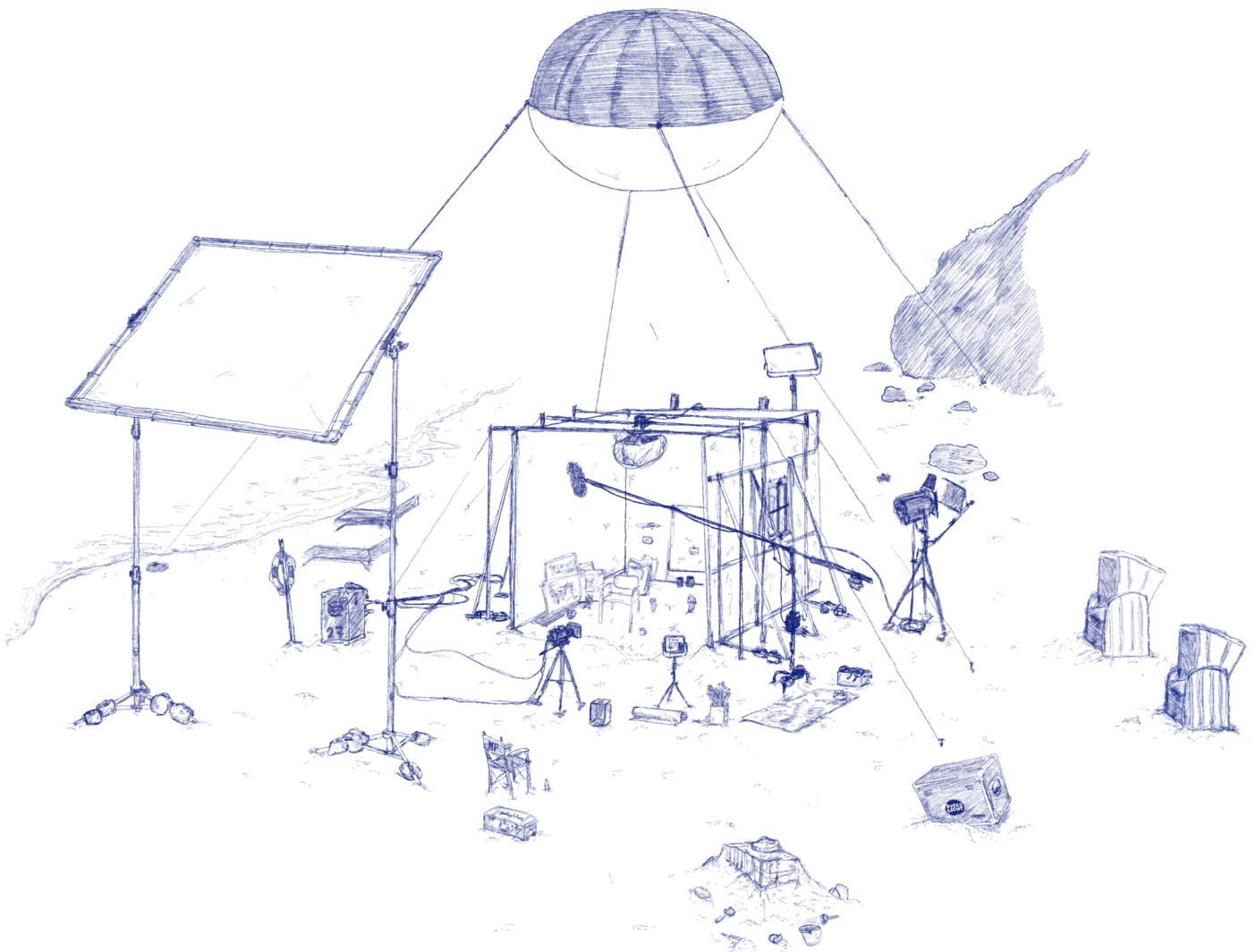

TORTURE REFERENCE SOURCES

S. 8 Schröder Susanne.: Glitch in der Pinakothek der Moderne München | Kuratorin Kunze: Ohne Fehler entwickeln wir uns nicht, In: Sonntagsblatt [https://www.sonntagsblatt.de/artikel/glitch-kunst-ausstellung-pinakothek (11.11.2024)].

S. 26 O. A.: Fremdes Werk in Pinakothek der Moderne, In: Pressemitteilung, Pinakothek der Moderne. [https://www.pinakothek-der-moderne.de/presse/fremdes-werk-in-pinakothek-der-moderne/ (11.11.2024)].

S. 27 O. A.: Mitarbeiter will berühmt werden – und schmuggelt eigenes Gemälde ins Museum, In: Süddeutsche Zeitung, 8. April 2024 [https://www.sueddeutsche.de/muenchen/muenchen-pinakothek-der-moderne-mitarbeiter-eigenes-bild-1.6532007 (11.11.2024)].

S. 28 Oltermann, Philip.: German art museum fires worker for hanging his own painting in gallery, In: The Guardian, 9. April 2024 [https://www.theguardian.com/world/2024/apr/09/german-art-museum-fires-worker-for-hanging-his-own-painting-in-gallery (11.11.2024)].

S. 26 Binswanger, Julia.: Employee Quietly Sneaks His Own Painting Onto the Walls of a German Museum, In: Smithsonian Magazine, 12. April 2024 [https://www.smithsonianmag.com/smart-news/museum-employee-illicitly-hangs-his-own-painting-in-munichs-pinakothek-der-moderne-180984136/ (11.11.2024)].

S. 28 Ables, Kelsey.: Museum fires employee for hanging up his own artwork, In: The Washington Post, 11. April 2024 [https://www.washingtonpost.com/entertainment/art/2024/04/11/art-museum-fire-employee-painting-germany/ (11.11.2024)].

S. 28 Blumenthal, Emily und Stern, Chris.: German museum worker fired after hanging his own art in gallery, In: CNN, 12. April 2024 [https://edition.cnn.com/2024/04/10/style/museum-worker-fired-hanging-own-art-scli-intl/index.html(11.11.2024)].

S. 28 Howard, Jacqueline.: German gallery fires employee for hanging own art in exhibition, In: BBC News, 10. April 2024 [https://www.bbc.com/news/world-europe-68776528 (11.11.2024)].

S. 30 O. A.: Museum Fires Worker For Hanging His Own Painting, In: The View, 11. April 2024 [https://www.youtube.com/watch?v=iok3uMsMbcc&t=4s (11.11.2024)].

S. 31 Oltermann, Philip.: Revealed: the picture sneaked by employee into a German gallery, In: The Guardian, 13. April 2024 [https://www.theguardian.com/world/2024/apr/13/revealed-the-artwork-sneaked-into-a-german-gallery-by-an-employee-and-the-story-behind-it (11.11.2024)].

S. 32 Emmerlich, Simon.: Mitarbeiter-Bild in Pinakothek: Doch eine Kunstaktion? In: Bayerischer Rundfunk, 8. Mai 2024 [https://www.br.de/nachrichten/kultur/mitarbeiter-bild-in-pinakothek-der-moderne-doch-eine-kunstaktion,UBzfgLA# (11.11.2024)].

Michael Pfitzner & Andreas Familler
Glitch The Art That Interfered

Copyright & Licensing

This comic is the intellectual property of Michael Pfitzner & Andreas Familler.

We are happy to share our work with you under the Creative Commons Attribution-NonCommercial-NoDerivatives 4.0 International License (CC BY-NC-ND 4.0).

What this means for you:

- Share: You are free to download and share the comic with others.
- Attribution: You must give appropriate credit to the authors.
- Non-Commercial: You may not use this work for commercial purposes (selling it or using it for ads).
- No Derivatives: You may not remix, transform, or build upon the material. The artwork and text must remain in their original form.

For full license details, please visit: creativecommons.org
"keep the glitch alive"



PICTURE WAS ALREADY IN THE MUSEUM
EMPLOYEE SNEAKS HIS OWN PAINTING INTO MUSEUM

THE SÜDDEUTSCHE ZEITUNG (SZ) REPORTED ON MONDAY, APRIL 8 2024,
WITH REFERENCE TO MUNICH POLICE:

MISASSUMPTION → AN EMPLOYEE OF THE ~~(MUSEUM)~~ *PINAKOTHEK DER MODERNE* OF ~~(MODERN ART)~~ TRIED TO ACHIEVE HIS
ARTISTIC BREAKTHROUGH BY ~~SNEAKING~~ *PICTURE WAS ALREADY IN THE MUSEUM* HIS OWN PAINTING IN. THIS ~~UNUSUAL~~ *ARTISTIC*
ACTION HAD LEGAL CONSEQUENCES AND A QUICK CLARIFICATION OF HIS
EMPLOYMENT RELATIONSHIP.

THE 51-YEAR-OLD WHO WORKED IN TECHNICAL SERVICE AND ~~CALS HIMSELF~~ *JUST ARTIST*
FREELANCING ARTIST USED HIS ACCESS TO THE EXHIBITION SPACES OUTSIDE OF
OPENING HOURS FOR UNNOTICEDLY PUTTING UP HIS PICTURE.

THE PAINTING SIZED 60 BY 120 CENTIMETRES WAS ~~QUICKLY~~ *(NOT THAT QUICKLY)* IDENTIFIED AND
REMOVED BY THE MUSEUM.

THE MAN RECEIVED A HOUSE BAN AND WAS LAID OFF. THE EMPLOYMENT WAS
TERMINATED BY A CANCELLATION AGREEMENT.

THE EXACT NATURE OF THE ACTION REMAINS UNKNOWN.
TILL NOW...

*A PLEASANT TEXT THAT ENCOURAGES READING. WITH BETTER RESEARCH AND
A FEW STRUCTURAL IMPROVEMENTS, IT COULD BE EVEN STRONGER!*